



Release January 2020

CHILLER & REVERSIBLE CHILLER YUKON Series



Cooling capacities from 50 to 500kW with water 12-7°C
Water / brine operating range from + 10° C to -25° C



Enex presents YUKON GRAVITY, the innovative series of Chillers with transcritical cycle cooled by air, dedicated to cooling water and water/glycol mixtures. Its use is particularly suitable in all environments that require a significant quantity of hot water, such as hotels and hospitals, beside the production of cold water to different temperatures for both technical, process and comfort applications.

The series was conceived to facilitate and exploit heat recovery in a particularly efficient way. Enex has been the first company ever to develop CO₂ only solutions since 2004. CO₂ (R744) is a natural fluid with zero OPD, GWP = 1. Neutral refrigerant by excellence, CO₂ is neither toxic nor flammable: among natural gases it is in fact the one with fewer contraindications so that represents the perfect choice for the future, not subject to the F-gas regulation on fluorinated gases.

3 VERSIONS GRAVITY - EJECTOR - REVERSIBLE

The operating principle of standard version YUKON GRAVITY is with gravity-fed flooded evaporator which allows better temperature control and lower energy consumption. Alternatively, the EJECTOR version guarantees superior energy efficiency levels of over 12% per year, thanks to the use of the ejector (Enex patent) and its innovative principle.

The ejector is a device capable of recovering energy from the expansion of a gas/vapor flow and converting it into a pressure increase from a secondary flow. It can be used both as a liquid pump and as a compressor. The innovative method developed and patented by Enex allows to obtain maximum efficiency in a simple way.

The REVERSIBLE version exploits the principle of the heat pump, an element of extreme importance both in industrial and comfort applications, since it allows to generate fluids normally from 30-35 to 50 ° C (but also up to 65-80 ° C), depending on processes and different needs.

 enJECTOR® PATENTED

Patent Certificate N.
102017000130508 issued
by the Ministero dello
Sviluppo Economico
Italiano dated 31.01.2020

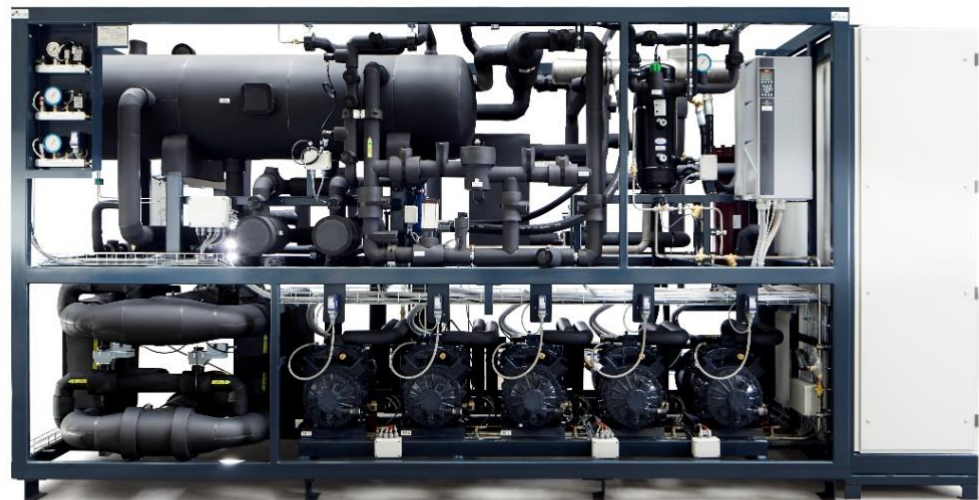

The image is for illustrative purpose and it is referred to CHILLER of the YUKON series Size STD 5-360

2 APPLICATIONS INDUSTRIAL - COMFORT

Chillers and reversible chillers of YUKON series are designed for both industrial and Comfort applications. They are very efficient when hot and cold water are required simultaneously for the different phases of processes (or simply to heat spaces or produce domestic hot water) with a smart energy recovery, resulting in both energy and economic savings. For example, a 100 kW chiller (cold water produced at 7 ° C with a return temperature from the system at 12°C) in recovery mode can produce about 50 kW of hot water, generating over 72000 thermal kWh of energy which leads to an approximately annual saving of € 4500 (in case of 12h per day operation, for 4 months per year and assuming a precautionary value of thermal kWh cost equal to 6 cents per kWh).

GENERAL TECHNICAL DATA

YUKON range consists of 8 sizes for the GRAVITY version, 3 sizes for the EJECTOR version and 6 sizes for the REVERSIBLE version, which can be declined with different options.

For these reasons, the technical data may vary according to the initial specifications provided and / or agreed with the customer. Below the main general technical data:

Model YUKON GRAVITY			1-65	2-120	3-170	4-230	4-280	5-300	5-360	6-440
Maximum Cooling Capacity	(1)	kW	64,1	119,5	164,6	227,9	272,2	293,0	350,0	431,1
Minimum Cooling Capacity		kW	33,8	37,7	33,4	37,9	42,7	42,9	42,7	42,9
Maximum Heating Capacity	(2)	kW	96,0	180,0	256,0	345,0	420,0	440,0	532,0	632,0
Minimum Heating Capacity	(2)	kW	50,6	56,3	49,8	57,0	64,7	63,7	64,0	64,7
EER compressors only	(1)		1,98	1,97	1,98	1,98	1,98	1,97	1,96	1,96
Seasonal Energy Efficiency Index SEPR	(3)		5,43	5,64	5,30	5,14	5,19	5,04	5,11	5,19

Model YUKON EJECTOR			2-120	3-170	4-230					
Maximum Cooling Capacity	(1)	kW	-	137,5	190,3	253,6	-	-	-	-
Minimum Cooling Capacity		kW	-	42,2	37,3	41,1	-	-	-	-
Maximum Heating Capacity	(2)	kW	-	180,0	256,0	345,0	-	-	-	-
Minimum Heating Capacity	(2)	kW	-	60,3	53,4	60,0	-	-	-	-
EER compressors only	(1)		-	2,27	2,30	2,21	-	-	-	-
Seasonal Energy Efficiency Index SEPR	(3)		-	6,00	6,10	6,10	-	-	-	-

Model YUKON REVERSIBLE			1-65/70	2-120/130	3-170/180	4-230/240	4-280/280	5-300/280		
Maximum Cooling Capacity	(1)	kW	64,1	119,5	164,6	227,9	272,2	293,0	-	-
Minimum Cooling Capacity		kW	33,8	37,7	33,4	37,9	42,7	42,9	-	-
Maximum Heating Capacity	(2)	kW	73,2	128,0	182,0	238,0	281,0	277,0	-	-
Minimum Heating Capacity	(2)	kW	34,5	41,0	63,0	84,0	43,8	43,5	-	-
Maximum Heat Recovery Capacity	(4)	kW	-	128,0	182,0	238,0	281,0	277,0	-	-
Minimum Heat Recovery Capacity	(4)	kW	-	41,0	63,0	84,0	43,8	43,5	-	-
EER compressors only	(1)		1,98	1,97	1,98	1,98	1,98	1,97	-	-
Seasonal Energy Efficiency Index SEPR	(3)		5,40	5,50	5,40	5,40	5,40	5,50	-	-

Dimensions panels included (gas cooler excluded)										
Lenght (L)	(5)	mm	1454	3180	3660	3981	4481	5450	5450	6050
Height (H)	(5)	mm	1931	2255	2260	2206	2206	2350	2350	2350
Width (W)	(5)	mm	1067	1100	1100	1155	1155	1510	1510	1510
Operation and transport weight	(5)	kg	850	2450	2800	3240	3490	3990	4020	4400

Noise levels panels included (gas cooler excluded)										
Sound Power Level		dB(A)	72	75	77	78	79	79	80	81

NOTES:

Express data are referred to standard conditions, for further information, and/or additions, please refer to the graphs shown in this brochure or contact Enex

(1) External air ambient temperature 35°C, water in/out 12°C/7°C

(2) Calculated with TOTAL heat recovery HT (Water In/Out 35/65°C; External Air Ambient temperature -5°C)

(3) Referred to European Regulation 2016/2281 (ECODESIGN), referred to standard gas cooler

(4) Calculated in heating mode (Water In/Out 35/50°C; External Air Ambient temperature -5°C)

(5) Values can be subjected to modifications

SPECIFICATION DESCRIPTION AND NOMENCLATURE

Frame structure: strong frame and painted with epoxy powders RAL5008 (other colors on request). Technical solution with flooded evaporator fed by gravity for better temperature control and lower energy consumption. Use of a natural refrigerant such as CO₂ (R744) with zero OPD, GWP = 1, non-toxic or flammable. Reversible version, with dedicated logic to optimize COP based on the required water temperature.

Reciprocating compressors optimized for operation under specific conditions, with separate manifolds thanks to the fusion design to limit oil temperature, with robust mechanical components, in particular piston pin and connecting rod.

High efficiency coalescent type oil separator, with inspection flange usable for periodic filter replacement.

Coolant storage tank: in painted carbon steel. The cold tank will be insulated with Armaflex or equivalent with closed cells, combined with protection, for cold parts, with fat bandage and vapor barrier.

Plate type evaporators in stainless steel AISI316L.

Oil storage tank: painted with epoxy powders. Oil management with level regulator for single compressor from storage tank.

Cladding paneling (if required): in painted galvanized sheet or in painted aluminum, with soundproofing sponge coating with rhombuses and heavy material sheet.

Piping: in AISI304L TIG welded stainless steel. Pressed stainless steel fittings. The pipes are clamped with industrial type fixings. Cold pipes are thermally insulated.

Step-motor regulation valve in stainless steel, mounted with shut-off valves and with optional mechanical backup valve. Alternatively, step-motor valve combined with ejector and second evaporator in series. Aluminum block ejector construction with removable cartridge.

Exchangers: the heat exchangers for heat recovery are of the AISI 316L stainless steel plate type. The regenerative exchanger is of the tube bundle type with high pressure inside the pipes and interceptable external by-pass. Coating with vapor barrier and closed cell rubber insulation.

Optional:

- Backup cooling unit
- System with ejector to further increase efficiency
- Heat recovery at high temperatures

Electrical panel with IP54 protection degree (galvanized sheet painted RAL 7035 textured) with first choice controllers:

- Disconnecter
- Contactors with thermal protection
- Automatic switches
- Inverter on one compressor minimum

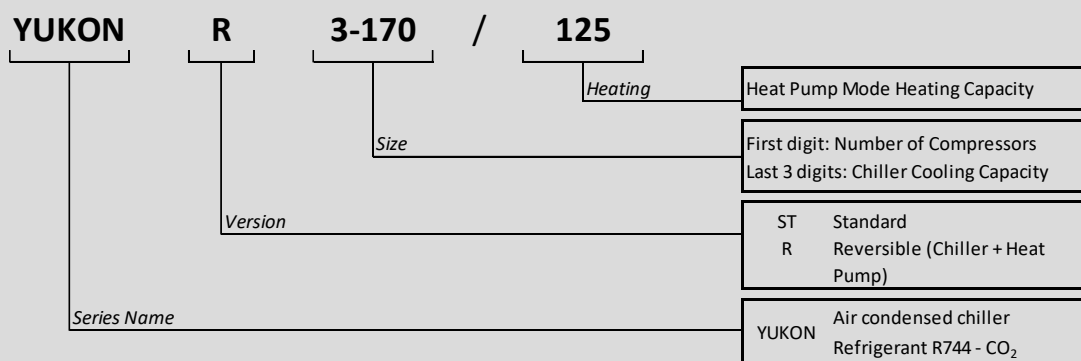

DISTINCTIVE TECHNOLOGICAL CHOICES OF THE RANGE

ENEX PATENTS and INNOVATIONS

Enex developed numerous innovations in the field of CO₂ refrigeration, some of which have given rise to important patents such as the "overfeeding of evaporators" and the "re-compression of flash vapor". Yukon units can be equipped with these exclusive innovations on request.

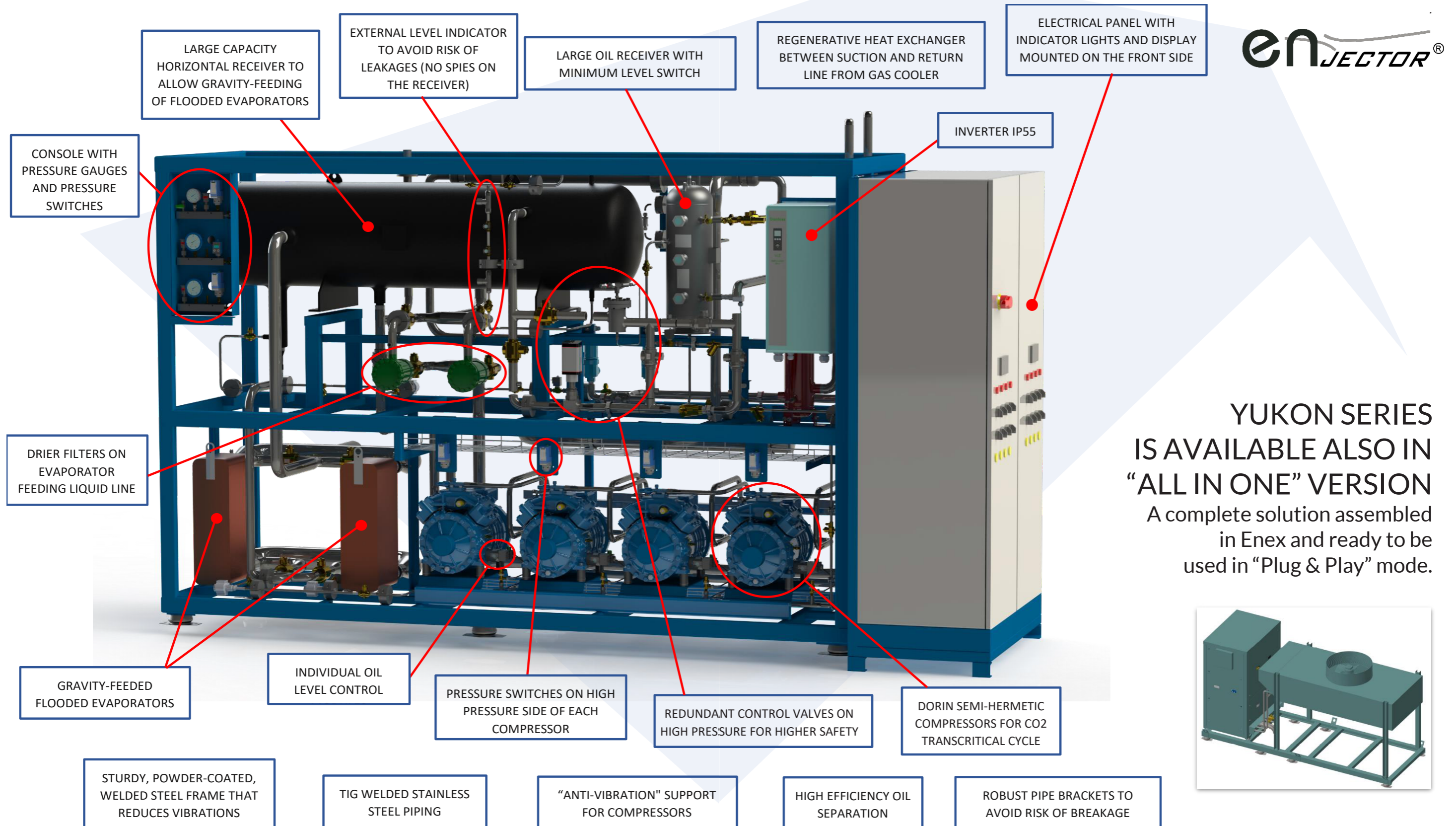

YUKON SERIES IS AVAILABLE ALSO IN "ALL IN ONE" VERSION
A complete solution assembled in Enex and ready to be used in "Plug & Play" mode.

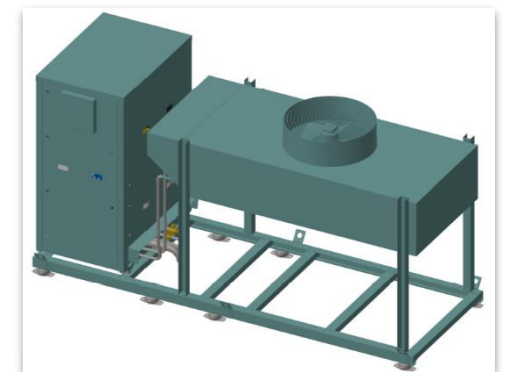

ENEX TECHNOLOGICAL ADVANTAGES

- ◆ Better temperature control and lower energy consumption thanks to the gravity flooded evaporator system;
- ◆ Efficiency further increased by using the optional system with ejector;
- ◆ Efficient heat recovery, even at high temperatures, particularly suitable for hotels, canteens, homes and production facilities (possibility of dedicated solutions also on-demand);
- ◆ No design restrictions, the use of a natural refrigerant such as CO₂ (R744) with zero OPD, GWP = 1, non-toxic or flammable;
- ◆ Not subject to restrictions of the F-gas regulation on fluorinated gases;
- ◆ Yukon reversible with COP optimized according to the required water temperature;
- ◆ Robust and compact structure, stainless steel pipes, low noise;
- ◆ Simplified maintenance thanks to easily accessible components;
- ◆ Simplified installation, the air-cooled condenser (Gas Cooler) can be installed even remotely from the main unit;
- ◆ Control and management via integrated ModBus remote supervision or via Carel Mini Boss (optional).

HIGH ENERGY EFFICIENCY

GRAVITY: EER values at the variation of external air ambient temperature

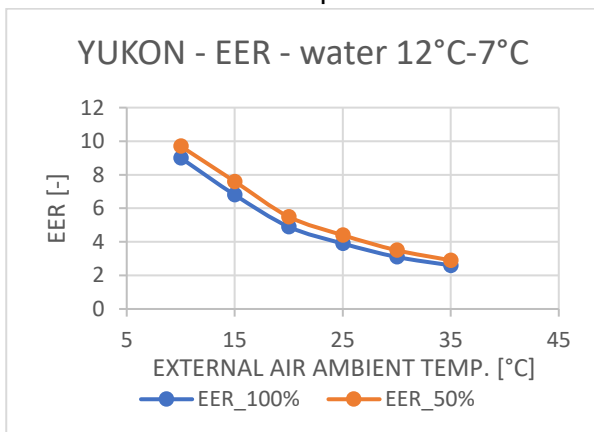

EJECTOR: EER values at the variation of external air ambient temperature

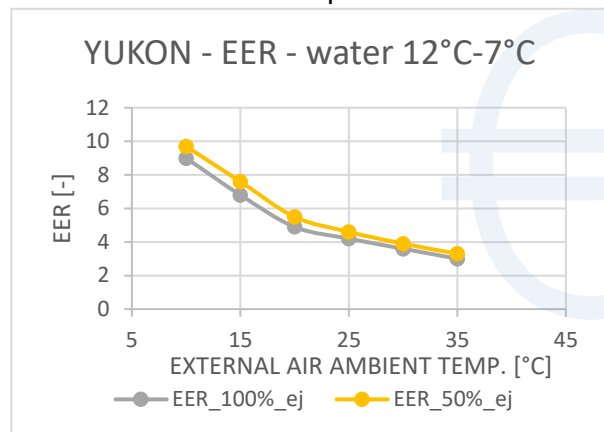

REVERSIBLE: COP with high Water side deltaT

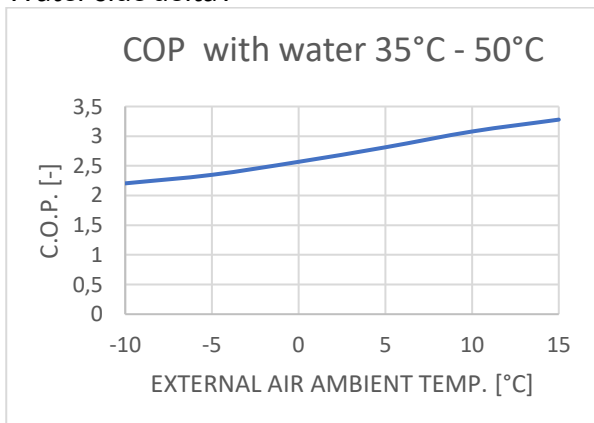

REVERSIBLE: COP with low Water side deltaT

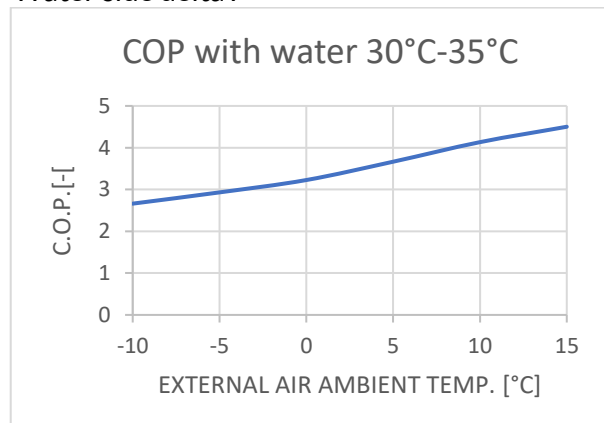



2004 ————— 1500 ————— 20 —————

Foundation year Transcritical systems installed Countries in the world where Enex is present

Publication: Commercial Brochure YUKON Series | Version January 2020 | ENG

Copyright © ENEX S.R.L. Società a Socio Unico
Via Veneto 12, 31038 Padernello di Paese (Treviso), Italy | VAT IT02328320300
Tel +39 0422 440429 | Fax +39 0422 961021 | info@enex.it | www.enex.it

All rights reserved in all Countries.

The technical data and information expressed in this publication are owned by ENEX S.R.L. and have general information. With a view to continuous improvement, ENEX S.R.L. has the right to make at any time, without any obligation or commitment, all the modifications deemed necessary for the improvement of the product, for this reason even substantial changes can be made to the documentation without notice. The example images of the products and components inside the units are illustrative and therefore any brands of the components functional to the construction of the units may differ from any brands represented in this document. This document has been prepared with the utmost care and attention to the contents displayed, nevertheless ENEX S.R.L. cannot assume any responsibility deriving from the use, direct or indirect, of the information contained therein.